

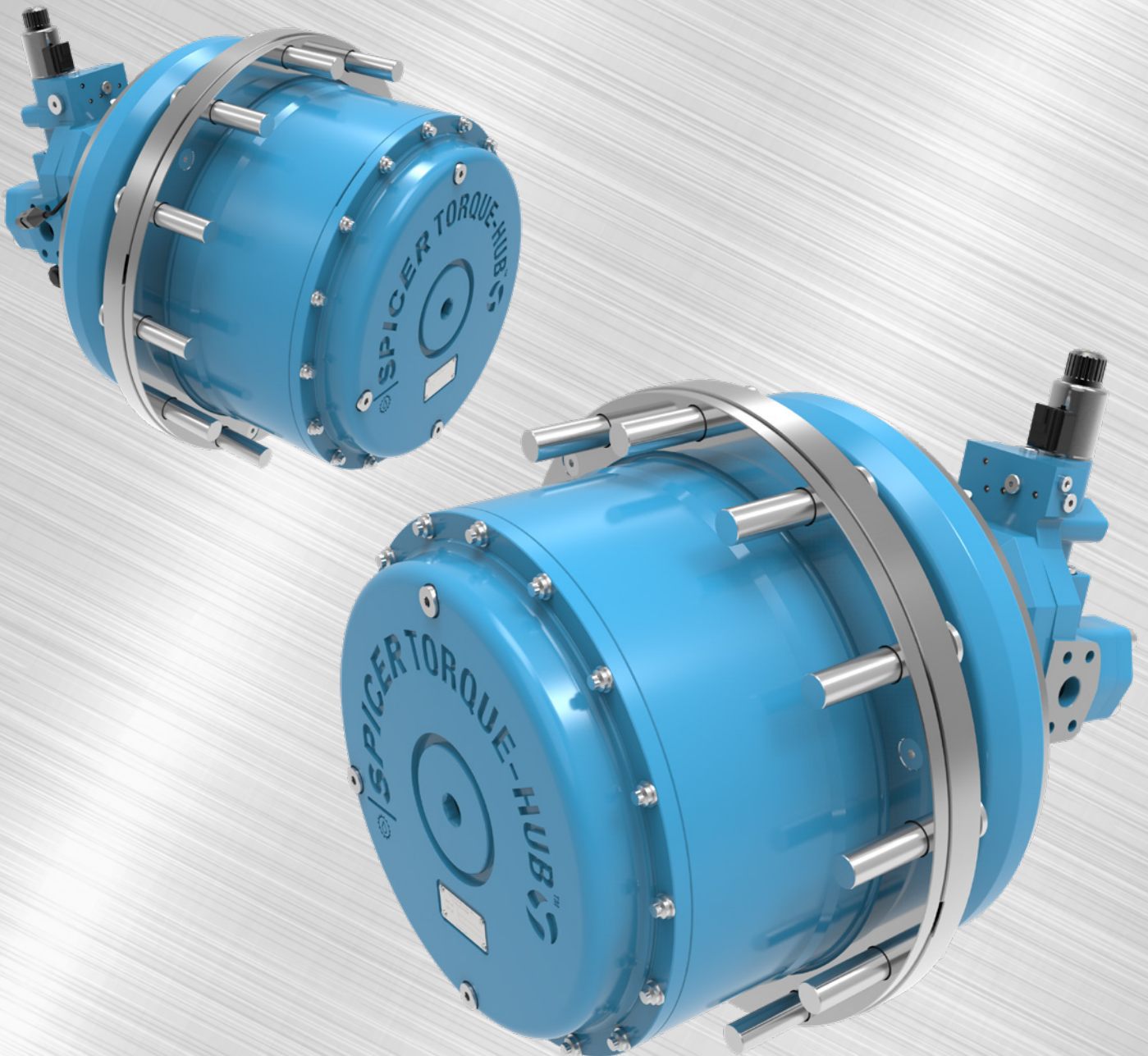

SPICER®
Torque-Hub®

Spicer® Torque-Hub® C0 Series Wheel Drive



*Spicer® Torque-Hub® C0 Series
specifically designed for today's
high-performance sprayers.*

C0 Series

Spicer® Torque-Hub® New C0 Series

With 50 years' experience with self-propelled sprayers, Dana took a fresh approach incorporating the best design features into the new C0 Series of Spicer® Torque-Hub® wheel drives. These features provide machine designers with the greatest flexibility to accommodate the current market demands for a range of machines, satisfying requirements for machine weight, speed, tire offsets, braking performance and durability.

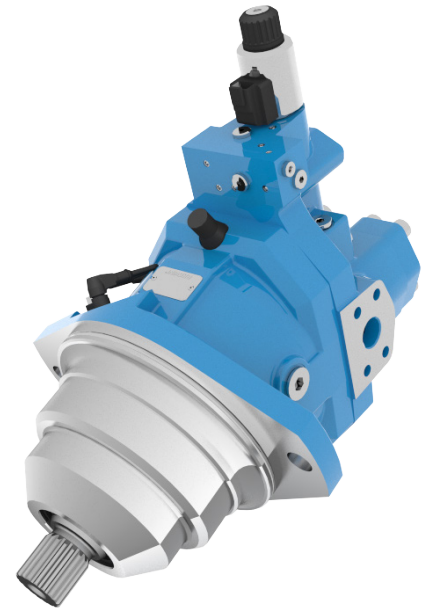
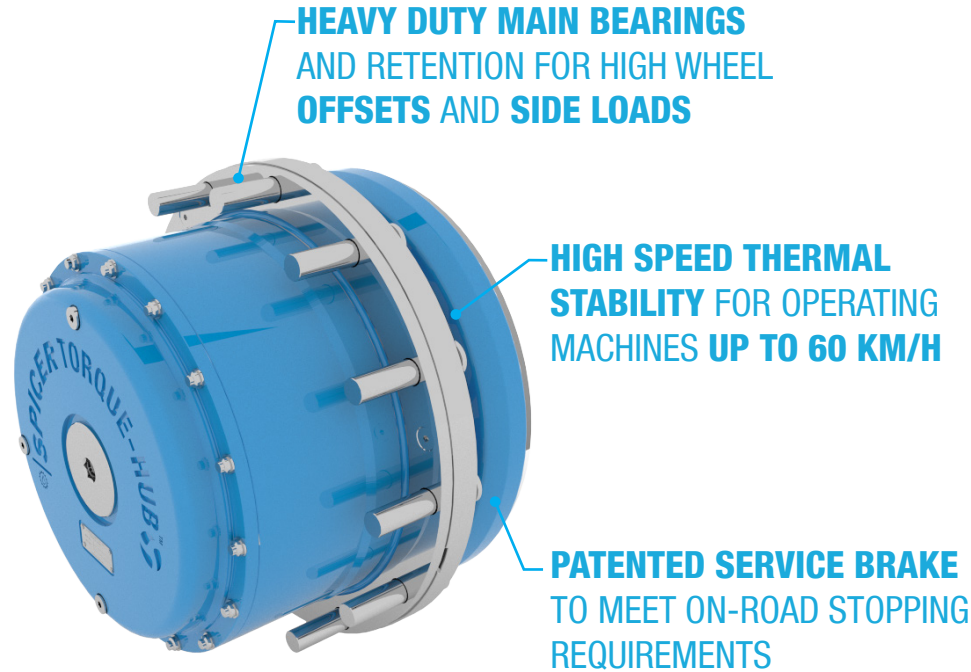

Additional Benefits

- 1 Product range specifically designed for modern high-performance sprayers
- 4 Products for machine capacities carrying from 2000 to 8000 liters
- Torque ratings from 16,000 Nm to 36,000 Nm
- Low maintenance requirements and easy to service
- Suitable for hydraulic and electric vehicles, with Dana's hydraulic and electric motors
- Easily integrated with central tire inflation systems (CTIS)

	C016	C021	C024	C036
Service Brake	▲	▲	▲	▲
Parking Brake	▲	▲	▲	▲
Disengage	▲	▲	▲	▲

▲ - Solution available

	C016	C021	C024	C036
A - Flange to Flange (mm)	96	135	135	135
B - Hub Length (mm)	168	156	171	200
C - Wheel Pilot Diameter (mm)	280	315	315	370
D - Wheel Bolt Circle Diameter (mm)	335	370	370	425

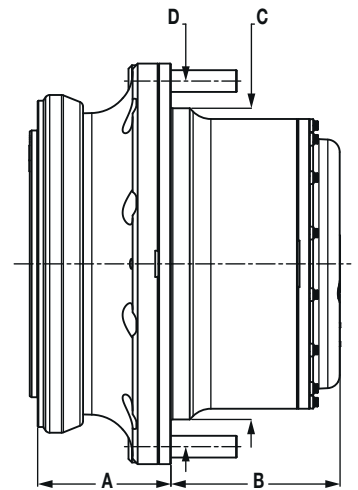

	C016	C021	C024	C036
Output Torque Rating	16,000 Nm	21,000 Nm	24,000 Nm	36,000 Nm
Ratio Range	24:1 - 34:1	22:1 - 35:1	22:1 - 30:1	22:1 - 27:1
Motor Mount	60cc Catridge	60cc & 80cc Catridge	80cc & 115cc Catridge	115cc Catridge
Machine Capacity	Up to 3000 L	Up to 3800 L	Up to 5000 L	Up to 8000 L

Dana.com/oh/contact

Application Policy

Capacity ratings, features, and specifications vary depending upon the model and type of service. Application approvals must be obtained from Dana; contact your representative for application approval. We reserve the right to change or modify our product specifications, configurations, or dimensions at any time without notice.

